



Maintenance Manual

Blast Chiller



Contents	Page
1 What is the Adande® System	4
2 Adande® Technology Explained	4
3 EC Declaration of Conformity	5
4 Storage of Product	6
5 Operating Adande® Temperature Settings	6
5.1 The Display Controls	6
5.2 Defrost	8
5.3 Drawer Alarm	8
5.4 Error Alarm	8
5.5 Temperature Alarm	8
5.6 Electrical Connection	9
5.7 Location and Stability	10
6 Insulated Container Removal	11
7 Worktop Removal	12
8 Front Grille removal	12
9 Left Hand Panel Removal	13
10 Rear Panel Removal	13
11 Drawer Front Removal	14
12 Drawer Switch Replacement	15
13 Removing the Diffuser	16
14 Evaporator Fan Replacement	17
15 Secondary Blast Chill Fan Replacement	18
16 Drain Tray and Defrost Heater Removal and Replacement	19
17 Evaporator Temperature Probes Replacement	20
18 Lid Heated Seal Replacement	21
19 Seal Height Adjustment	22
20 Runner Replacement	23

21	Condenser Fan Replacement	25
22	Electrical components	26
23	Electrical Control System	26
	23.1 Wiring Diagram for Dixell XB570L Controller	28
24	How to enter setting on Dixell XB570L Blast Chill Controller	29
	24.1 How to enter setting for each cycle	29
	24.2 settings for Dixell XB570L Blast Chill Controller	30
25	Refrigeration Maintenance	34
26	Drawer configurations	35
27	Fault Finding	37
	27.1 Drawers not operating correctly	37
	27.2 Seals and/or container rim have ice and condensation	37
	27.3 Drawer is not maintaining set temperature	37
	27.4 The drawer does not power up	38
	27.5 Evaporator fans run when drawer is open	38
	27.6 Evaporator fans do not run when drawer is closed	38
	27.7 Blast chill cycle fails to operate	38
28	Exploded diagrams	39
	28.1 Housing Spare Parts	39
	28.2 Fridge Electrical System and Drawer Parts	40
	28.3 Insulated Lid Parts	41
	28.4 Base with Standard Castors Parts	42
	28.5 High Castor Base Parts	43
	28.6 Small Castor Base Parts	44
	28.7 Double Wheel Castor Base Parts	45
	28.8 Large Rollers and Feet Base Parts	46
	28.9 Small Rollers and Feet Base Parts	47
	28.10 Top Cover	48
	28.11 Worktop and Upstand	49
	28.12 Heat Shield worktop	50

Welcome to Adande® Refrigeration

1 What is Adande®

Adande® is a new method of cold storage developed as a series of refrigerated drawers that offer storage temperature flexibility in 1°C increments between –22°C and +15°C.

Each refrigerated drawer:-

- Provides stable temperature storage
- A removable container to act as temporary cool and safe product storage.
- Gives full plan area access providing space efficient storage.
- Is easily cleaned or replaced.
- Can be supplied configured as a blast chiller.

2 Adande® Explained

Adande® uses standard technology and refrigeration parts but in a completely new and patented way.

A dedicated fridge engine supplies refrigerant to an evaporator coil assembly. The evaporator coil assembly then supplies cooling to the insulated container and is sized to maintain up to 40kg of product at any set point temperature, in the range of –22°C to +15°C.



Figure 1: Front view of Adande® Single Drawer

3 EC Declaration of Conformity

We declare that the following machinery complies with the essential health and safety requirements of the :-

The Machinery Directive 2006/42/EC.

The Low Voltage Directive 2006/95/EEC.

The Electromagnetic Compatibility Directive 2004/108/EC.

The Pressure Equipment Directive 97/23/EC.

Machinery Description: 1 Drawer Appliance for Chilled Storage.

Make: Adande®.

Type: Adande unitary drawer refrigeration

Manufactured by Adande Refrigeration Ltd.,

45 Pinbush Road, South Lowestoft Industrial Estate, Lowestoft, Suffolk
NR33 7NL

The following transposed harmonised European Standards have been used:

EN ISO 12100 parts 1 & 2 Safety of Machinery – Basic concepts, general principles for design.

EN ISO 13857 Safety of Machinery – Safety distances to prevent danger zones being reached by the upper and lower limbs.

EN ISO 13732-1: 2006 Ergonomics of the thermal environment -- Methods for the assessment of human responses to contact with surfaces -

- Part 1: Hot surfaces.

EN 1672-2 Food processing machinery – Basic concepts – Part 2 : Hygiene requirements

EN 61000-6-3:2001, Electromagnetic compatibility (EMC) - Part 6-3: Generic standards; Emission standard for residential, commercial and light- industrial environments

EN 61000-6-1 Generic Immunity Standard; Residential commercial and light industrial environments.

EN 60335-2-24 The Safety of Household and Similar Electrical Appliances – Part 2 –24: Particular Requirements for Refrigerating Appliances and Ice Makers.

EN 60335-2-89:2010 Household and Similar Electrical Appliances – Safety - Part 2 –89: Particular Requirements for commercial refrigerating appliances with an incorporated or remote refrigerant condensing unit or compressor.

The technical file for this machinery will be prepared on demand by :-

Name: Ian Wood

Position: Managing Director

Who also signs on behalf of the manufacturer

ADANDE® REFRIGERATION

45 Pinbush Road

South Lowestoft Industrial Estate

Lowestoft

Suffolk

NR33 7NL.

4 Storage of Product

For the drawer to operate at full efficiency the heated seal should be maintained in good condition. It is essential that the product is not stored above the **"MAX FILL LEVEL"** line as this can damage the seal and affect the operation of the drawer.

The drawer is capable of storing any food product. However, products which may give off acidic odours like vinegar, onions, etc. should be suitably sealed. Adande® also recommends storage containers with liquid food products be stored with lids.

Ensure that the product is never stacked above the **"MAX FILL LEVEL"** Label in the insulated container.

5 Operating Adande® Temperature Control System

The Adande® temperature control system allows you to set and control the drawer within a temperature range of -22°C (-8°F) and +15°C (59°F).

Temperature accuracy in the drawer will be maintained within $\pm 2^{\circ}\text{C}$ of the set point

5.1 The Display Controls

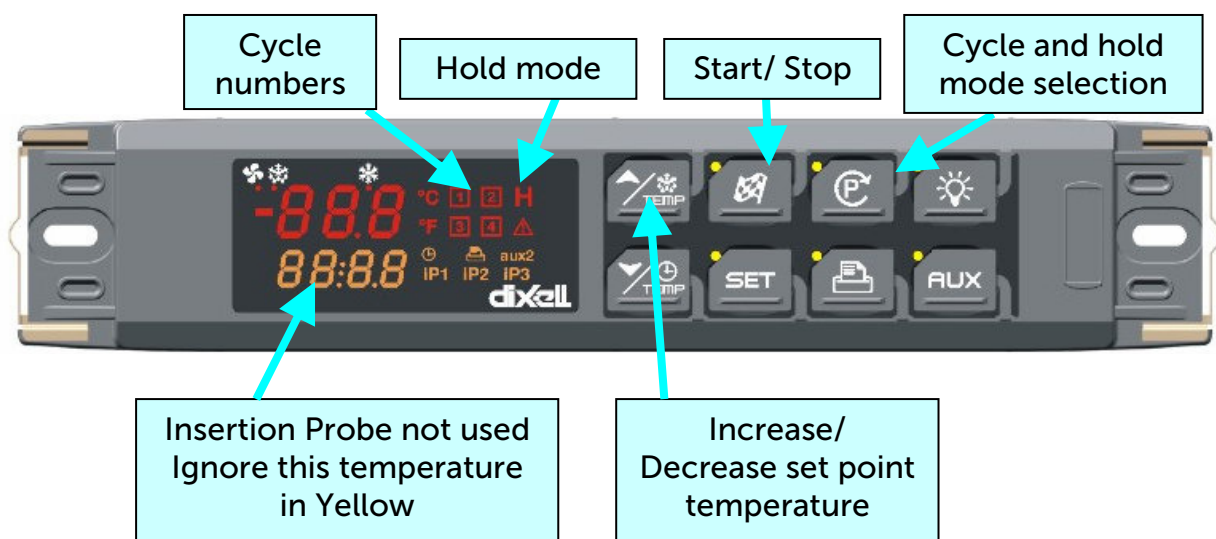

To Blast Chill

1. To stop the cycle push and hold the START/ STOP button  until the yellow light turns off.

2. Push and release the  button until the desired cycle is selected. The cycle number selected will be highlighted.

Cycle	Blast mode	1 st Phase - Hard Chill		2 nd Phase - Soft Chill		Total cycle duration (min)
		Duration (min)	Temperature (°C)	Duration (min)	Temperature (°C)	
1	Soft Chill			90	-1	90
2	Hard Chill	60	-15	30	-1	90
3	Soft Chill			120	-1	120
4	Hard Chill	80	-15	40	-1	120

3. Push and release the START/ STOP button  the yellow light will be switched on indicating that the blast chill cycle has started.



Normal Operation

For **normal refrigeration or frozen storage** push  button until the 'H' appears on the display and no cycle numbers are lit.



To change temperature push and release the  button this will show the current set point.

Then push and hold down the  button and the word "SetH" will flash



Use the  and  buttons to either increase or decrease the set point temperature.

Push the  button again to store the new set point. If the set button is not pressed the temperature will revert back to previous setting.

Press  to activate the hold mode, the buttons  and  will be illuminated.

5.2 Defrost

The refrigeration system automatically defrosts. If a manual defrost is required then

press the manual defrost button/temperature up button  for 3 seconds.

5.3 Drawer Alarm

If the drawer is open for more than 10 minutes, the display in the control panel changes to "DA".

When the alarm has been activated, the Adande[®] drawer will alarm both visually and audibly.

To silence the audible alarm, press ANY button on the display, or close the drawer. The alarm light and flashing display will continue to show until the drawer has been fully closed.

NOTE: THERE IS NO COOLING TO THE INSULATED CONTAINER WHEN THE DRAWER IS OPEN.

5.4 Error Alarm

If display reads "rPF" or "EPF", a temperature probe has failed, and an engineer should be called.

The Adande[®] drawer will operate with a 15 minute on / 15 minute off cycle in the event of an "rPF" failure. This will help to maintain the stored product at a safe temperature, but precise temperature control will be lost. "EPF" will only affect defrosts, and these will be timed to maintain operation of the drawer. An engineer should be called as soon as possible for either fault.

5.5 Temperature Alarm

Should "HA" appear on the display, the drawer temperature has exceeded its set point by 7°C and product core temperature should be checked. If the Adande[®] drawer has recently been turned on, loaded with warm product or left open for a long period of time, this alarm may be displayed. If the temperature does not return to the set point temperature, an engineer should be called.

Should "LA" appear on the display, the drawer temperature has fallen below its set point by 7°C and product core temperature should be checked. If the Adande[®] drawer's temperature set point has recently been increased, this alarm may be displayed. If the temperature does not return to the set point temperature, an engineer should be called.

5.6 Electrical Connection

The Adande® drawer should be connected to a 230V, single phase, 50 Hz, standard socket outlet supply. The drawer is connected to the mains supply with a detachable supply lead, one end of which is fitted with a standard 13 amp 3 pin plug (fused at 13A). The other end of the supply lead, fitted with an appliance plug, is connected to the Adande® drawer as shown in *figure 3a* below.



Figure 3a: Mains connection point

The unused socket on the right hand side in *figure 3a* can be used to provide a mains supply to additional Adande® Drawers as shown in *figure 3b* below.



Figure 3b: Mains connection point

DO NOT REMOVE ACCESS PANELS WITH THE ELECTRICAL SUPPLY CONNECTED.

5.7 Location and Stability

It is important that the Adande® drawer is installed and maintained on a flat, clean and level surface to ensure correct operation.

The room should be dry and sufficiently ventilated.

Optimum performance is obtained at ambient temperatures between +16°C (60°F) and +38°C (100°F).

The air outlet grill MUST be kept clear at all times to maintain optimum performance.

The Adande® drawer can be mounted on rubber feet, rollers or castors. When mounted on a castor base, the front two castors should have their brakes ON during normal use as in *figure 4*.



Figure 4: Lockable Castor

If the Adande® drawer is mounted on two rollers at the rear and rubber feet at the front, then to move the drawer either lift the front as shown in *figure 5* and push or pull into position, or use an open drawer as a lever to lift the drawer as shown in *figure 6*, this method may be preferable if drawers are stacked more than one high.



Figure 5



Figure 6

THE INSULATED CONTAINER SHOULD BE UNLOADED BEFORE MOVING

6 Insulated Container Removal

For many of the maintenance procedures the insulated container will need to be removed to allow for access. To remove the insulated container, first pull the drawer out fully so that the rear edge of the container clears the front and the runners are fully extended. Then as the photo below shows (*figure 7*) lift the container vertically up to remove (two people should lift the container out if still filled with product).



Figure 7: Removing the insulated container

7 Worktop Removal

To remove the worktop, first remove the 4 off M5 X10 bolts from the rear of the drawer, lift the rear of the worktop and push slightly forward to slide over and clear from the front retaining slots (*figure 8*). Replacement is the reverse of the removal procedure.

NOTE: CORRECT LIFTING PROCEDURES SHOULD BE FOLLOWED



Figure 8: Worktop removal

8 Front Grille Removal

To gain access to the electrical components it is necessary to remove the front grille, to do this first remove the insulated container from the drawer, loosen the 2 off M5 X 8 ST/ST bolts located inside the drawer space, and loosen the 2 off M5 X 8 ST/ST screws located externally at the side of the drawer. The front grille can now be removed by pulling forward at the bottom and then down. (*figures 9/10*).

NOTE: POWER MUST BE ISOLATED BEFORE REMOVING ANY PANELS

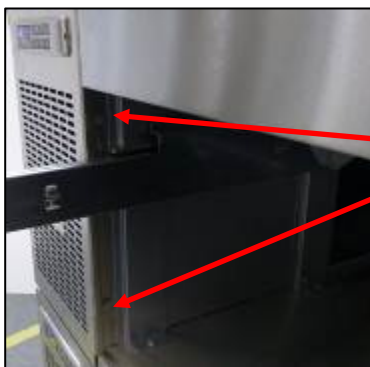

Figure 9



Figure 10

9 Left Hand Panel Removal

To gain access to the compressor, the left hand panel must be removed from the drawer, to remove this panel the 4 off M5 X 8 ST/ST screws on the side of the drawer and 2 off M5 X 8 bolts from the rear of the drawer must be removed as shown in *figure 11*, then slide the panel down and out.

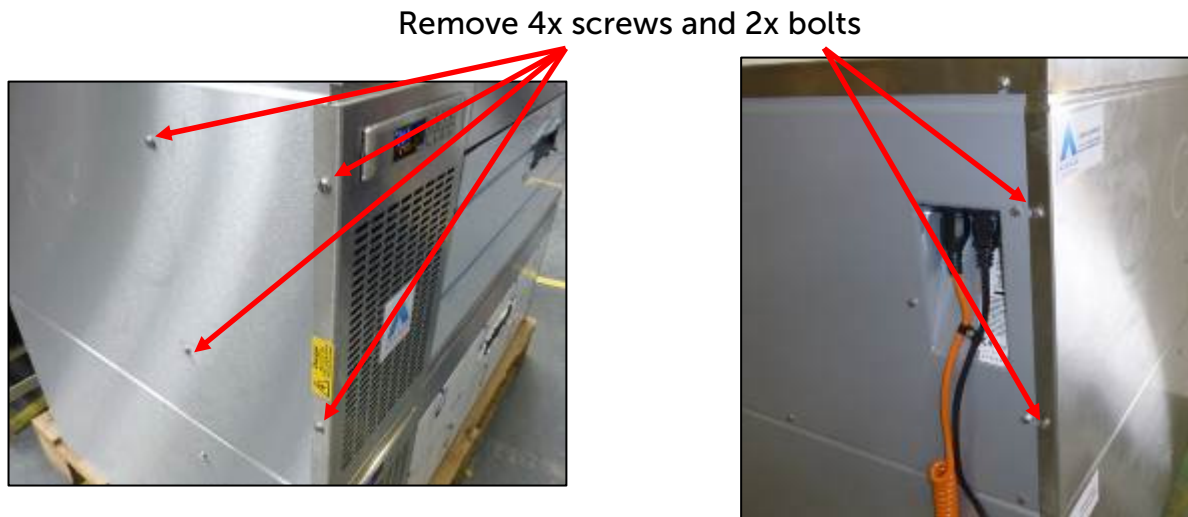

Figure 11: LH side fridge engine access panel removal

10 Rear Panel Removal

The rear panel of the drawer may require removal to gain access to the drain pipe or assist in diffuser and heated seal replacements. To remove the back panel, remove all 13 off M5x10 ST/ST bolts as shown in *figure 12* below.



Figure 12: Rear panel removal

11 Drawer Front Removal

To remove the drawer front you will need to remove the 4 off M5 Br.Zn.Pd. Nyloc nuts and 4 off M5 X 10 St/Steel bolts as shown in *figure 13* below.

NOTE: WHEN REPLACING DRAWER FRONT LOCTITE SHOULD BE USED ON THE SCREWS



Figure 13: Removing the four nyloc nuts and four bolts

Once these fixings are removed the drawer front will now slide off as shown below in *figure 14* below.



Figure 14: Removing the drawer front

12 Drawer Switch Replacement

To gain access and/or replace the drawer switch, remove either the insulated container and worktop (Chapter 6 and 7) or the Insulated container and side panel (Chapters 6 and 9).

Remove the Spade Connectors from the back of the switch and push the switch through into the drawer cavity as shown in *figure 15* and *16*.



Figure 15: Spade connectors connected to the drawer switch

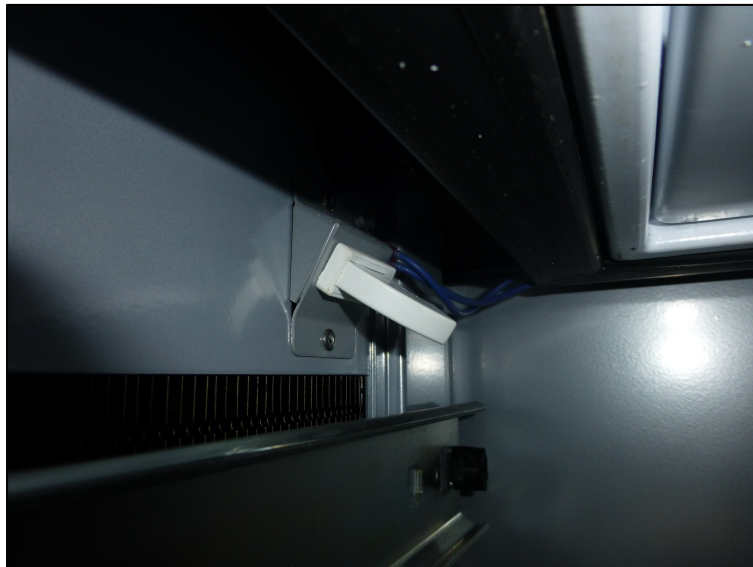

Figure 16: Drawer switch mounted on the Inner Wall Side Panel

13 Removing the Diffuser

To remove the diffuser the Insulated container will first need removing to allow access (Chapter 6). To remove the diffuser from the lid the 4 off plastic pozi screws and 4 off slotted ST/ST screws will need removing as shown in *figure 17*. This will allow the diffuser to be lowered for access.

NOTE: THE DIFFUSER WILL BE CONNECTED TO THE DRAWER BY THE EVAPORATOR FAN WIRES AND SECONDARY AIR CIRCULATION FAN WIRES

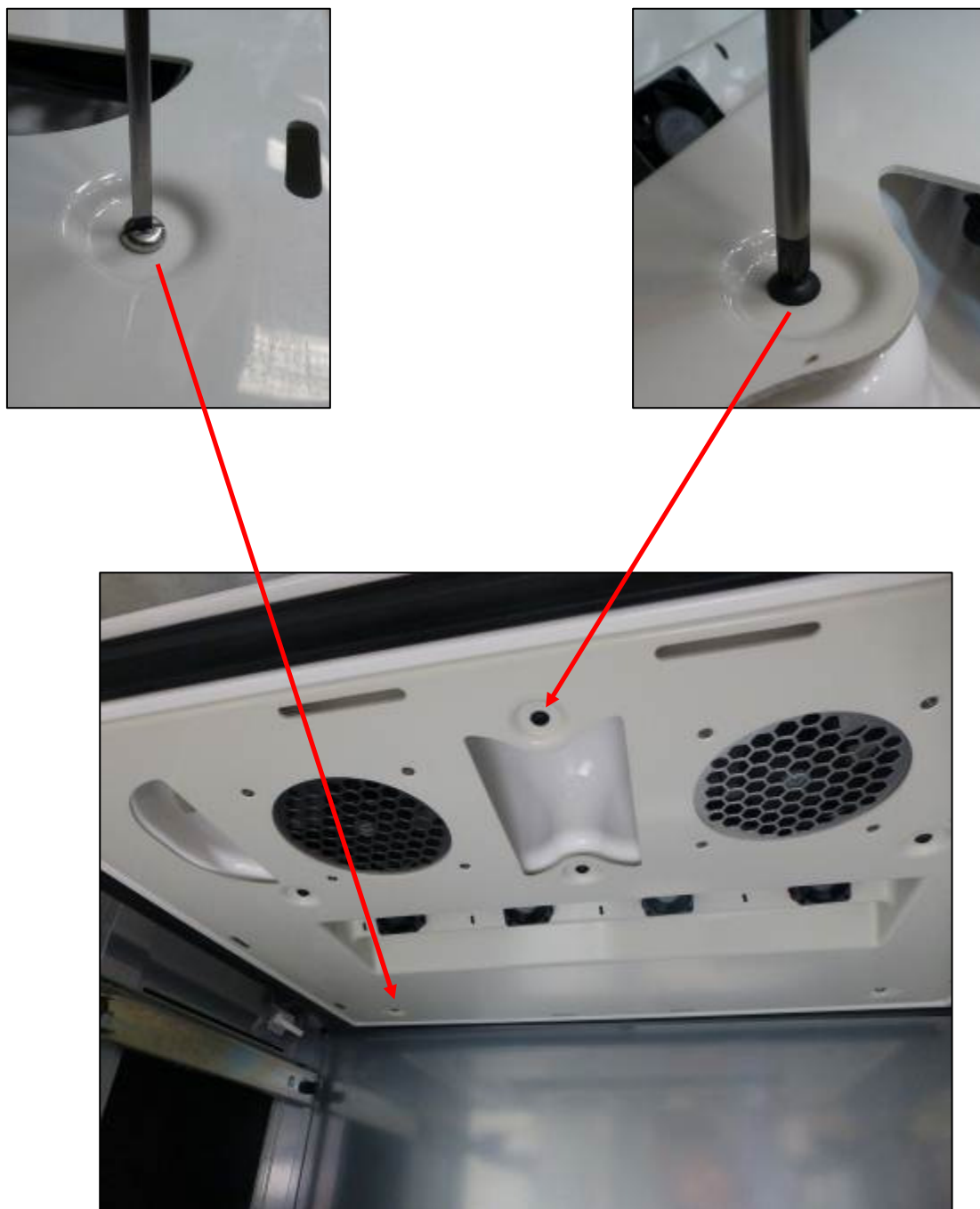

Figure 17: Lid Diffuser

14 Evaporator Fan Replacement

Once the diffuser is removed, the small evaporator fans can be removed first by cutting the wires at the **FAN** end and use these to pull through the wires attached to the new fan. Now remove the four self tapping screws that hold the fan in place as shown in *figure 17a*.

The fan wires need to be disconnected from the 12volt power supply within the controller enclosure, pulling the new wires through the hole in the lid (as shown in figure 16c below) fit bullet crimps to the new fan wires and connect to the 12volt power supply, mount the fans back on the diffuser as shown below in *figure 17b*. Replace all cable ties.



Figure 17a: Evaporator fans

4 Off per Fan Self Tapping screws

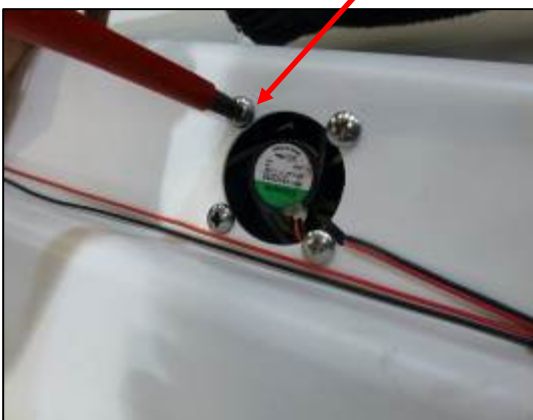

Figure 17b

hole in lid for all wiring



Figure 17c

15 Secondary Blast Chill Fan Replacement.

Once the diffuser is removed, the secondary blast chill fans can be accessed for removal first by cutting the wires at the Fan end and use these to pull through the wires attached to the new fan. Now remove the four screws that hold the fan and guard in place as shown in *figure 18*.

The fan wires need to be disconnected from the 24volt power supply within the controller enclosure, pulling the new wires through the hole in the lid (as shown in *figure 17c*) fit bullet crimps to the new fan wires and connect to the 24volt power supply, mount the fans back on the diffuser as shown below in *figure 18*. Replace all cable ties

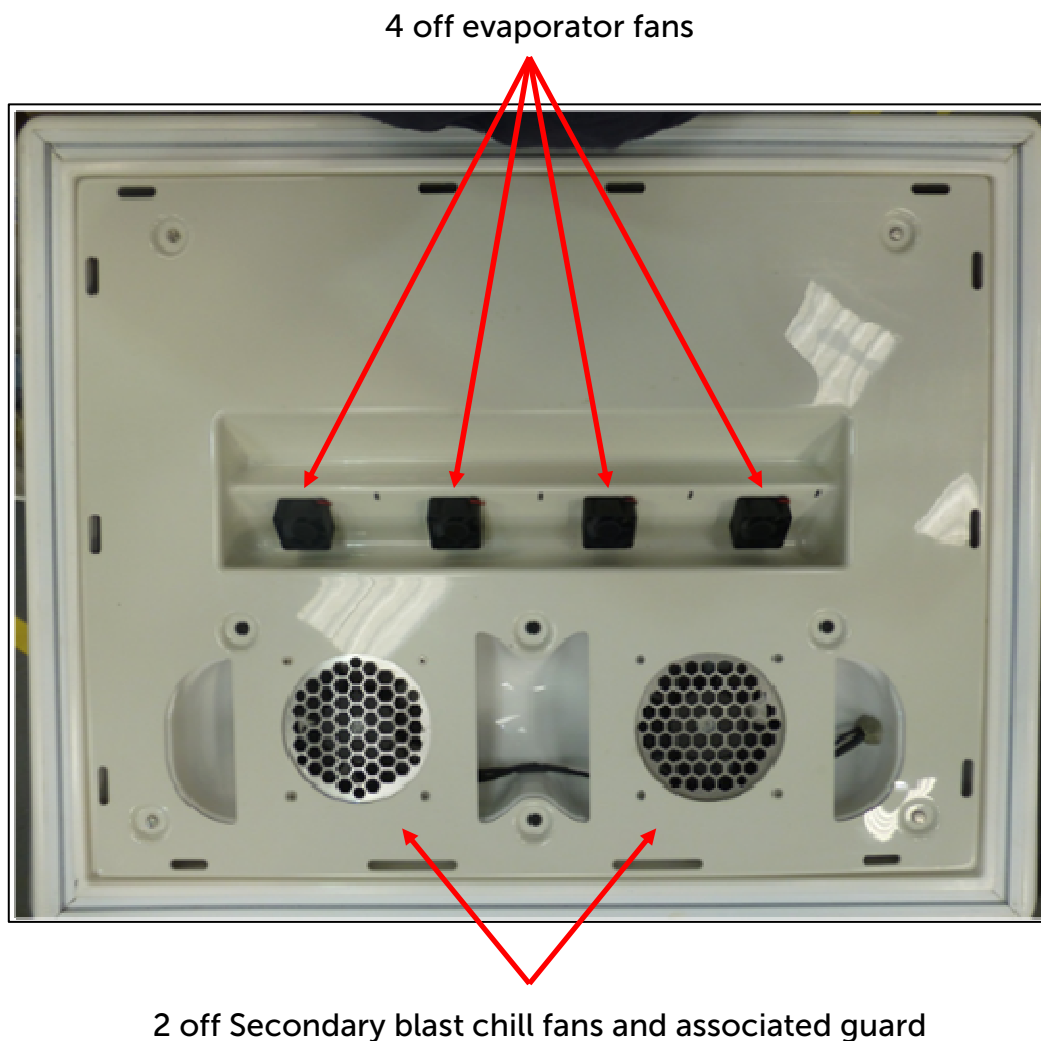

Figure 18: Diffuser showing evaporator fans, secondary blast chiller fans and 8 off diffuser retaining screws

16 Drain Tray and Defrost Heater Removal and Replacement

To remove the drain tray the insulated container, rear panel and diffuser will need to be removed. (Refer to chapters 6, 10 & 13) Once this has been done remove the drain pipe and putty from the back of the lid as shown in *figure 19* below.

Now remove the wires for the defrost heater from the controller. (Refer to Chapters 21 and 22)

NOTE: ATTACH A SPARE PIECE OF DRAW WIRE TO THE OLD HEATER WIRES BEFORE PULLING WIRES OUT TO AID PULLING THROUGH NEW HEATER WIRES.



Figure 19: Drain pipe and putty

Remove the four M5 X 10 bolts and associated sealing washers fixing the drain tray to the evaporator, drop down the drain tray complete with defrost heater and remove. (*figure20*)

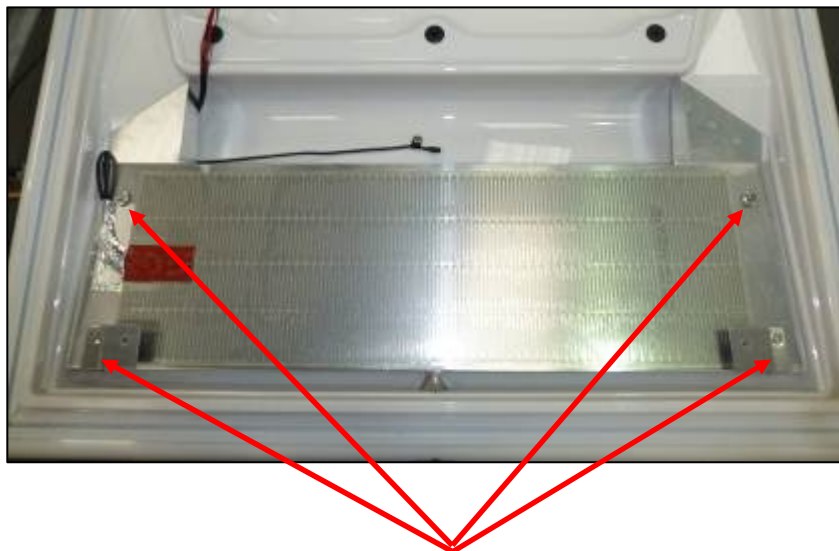

Figure 20: Remove four bolts and sealing washers to release drain tray note position of 2 diffuser retaining brackets

When replacing the drain tray take care not to bend the tray or the water may not drain correctly, ensure all four sealing washers are on the four fixing bolts. Replace drain tray and apply putty around drain pipe penetration both inside and outside of lid.

17 Evaporator Temperature Probes Replacement

To replace a faulty temperature probe the insulated container, diffuser and drain tray will need to be removed. (Refer to chapters 6, 13 & 15) to gain access to the evaporator coil. Remove the P-Clips holding the probes in place and the refrigeration putty from wire penetration in lid.

Disconnect the faulty probe from the controller, pull the probe wires through the lid and remove from the drawer. Install the new probes back through the electrical wire penetration hole in the lid and re connect to controller, replace the P-Clips as shown in *figure 21* and repair/replace the refrigeration putty at the wire penetration of the lid.

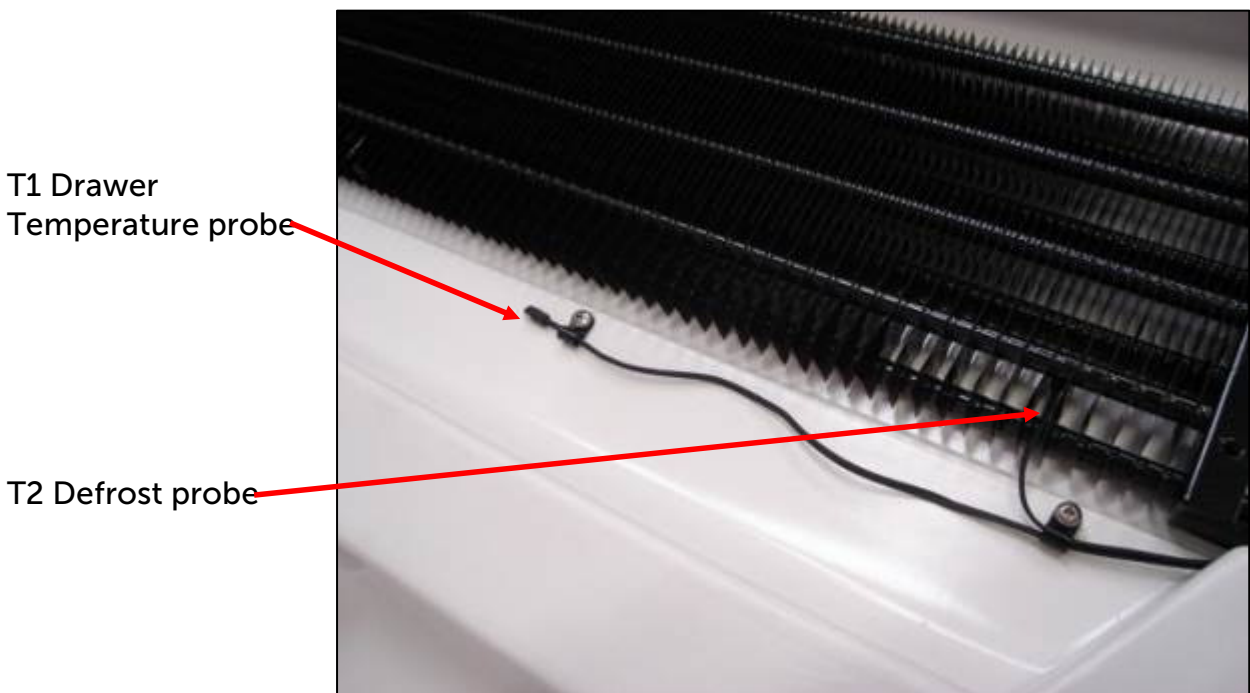

Figure 21: Temperature probes held in place with P-Clips

18 Heated Seal Replacement

To replace the seal first remove the insulated container (Chapter 6). Then pull the heated seals wires through the inner wall from the compressor housing into the drawer cavity and disconnect the Bullet connectors; this disconnects the heating element from the 12v power supply.

Pull the seal out of the retaining channel in the lid and replace with a new seal (Push seal into corners of the retaining channel first for alignment). Reconnect the Bullet connectors and pass back through the Inner Wall into the compressor housing to prevent it snagging on the drawer or runner when closed.

On completion of seal replacement the lid height should be checked refer to Chapter 19.

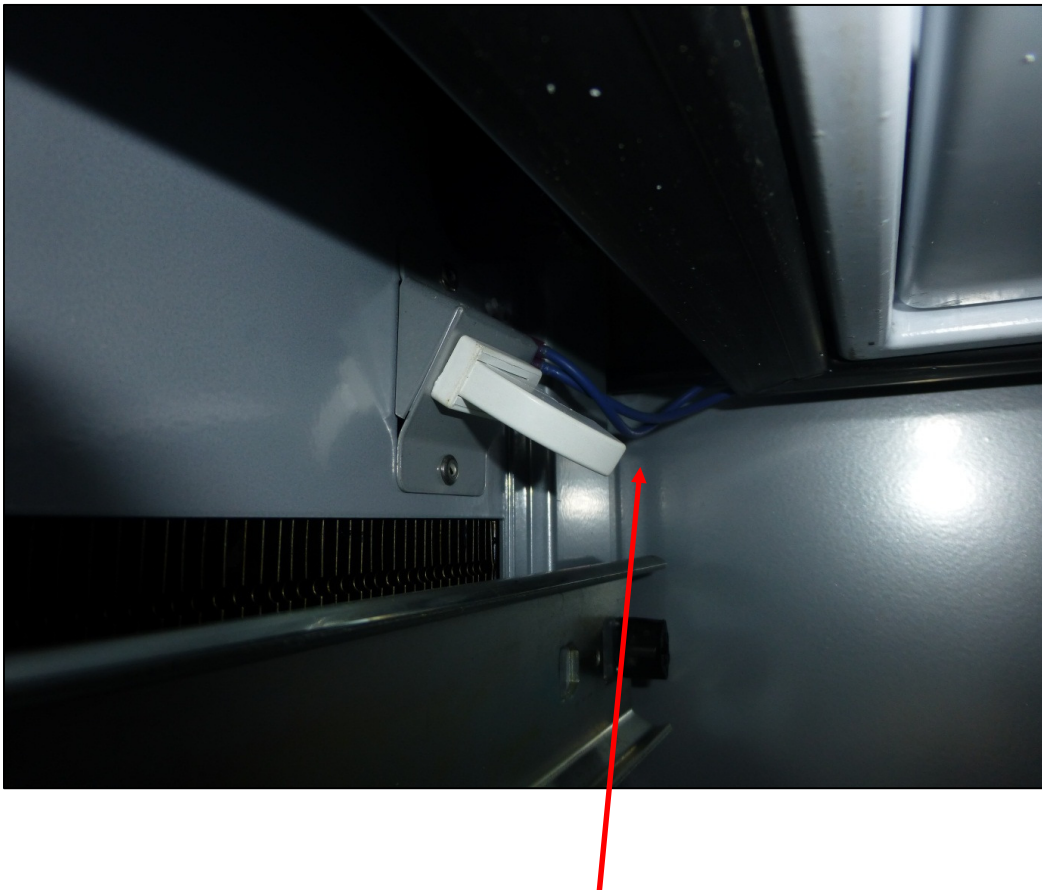

Figure 22: Heated seal wires and Inner wall penetration

19 Seal Height Adjustment

The seal and lid height is critical to ensure:

- The correct closure and opening of the drawer
- To prevent the insulated container icing closed
- To prevent access of warm ambient air into container

Lid Height adjustment is done by loosening the 4 lid mounting screws, 2 are located behind removable caps on the RH side panel and 2 within the compressor housing (as shown below with the worktop removed in figures 22a and b). The two rear corners should be adjusted first, apply a small amount of pressure and tighten, then adjust the two front corners by loosening the screws and letting the lid rest under its own weight.

To adjust the lid height on a drawer that is stacked, while the screwdriver is located in the screw head lever the lid up or down as required, repeat the process for all screws until the desired height is achieved.

NOTE: DO NOT OVER COMPRESS THE SEAL

To check that the seal isn't over compressed, open the drawer and ensure there is a 2mm gap between the back edge of the insulated container and the front edge of the seal (container and runners are at a slight angle to the lid).

To prevent a new seal sticking to the rim of the insulated container it is recommended that the seal is lubricated with a silicone based plastic/ rubber lubricant.

Lid mounting screws

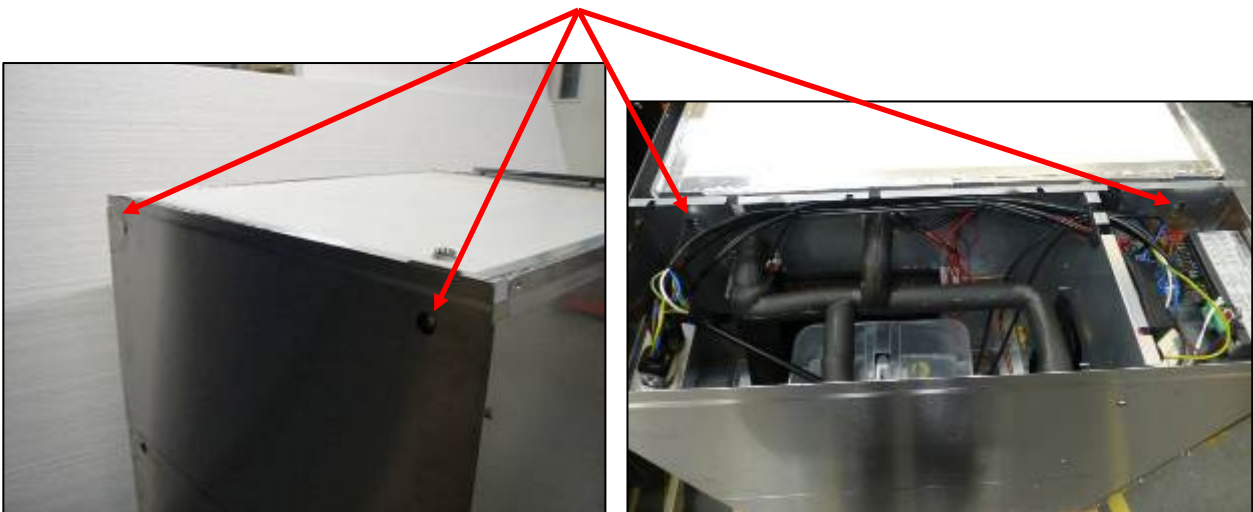

Figure 22a and b: Lid mounting screws when worktop is removed

20 Runner Replacement

To replace a drawer runner the Insulated container and drawer front will need to be removed to gain access (Chapters 6 & 9).

First remove the container support from the failed runner by removing the M5 X 6 ST/ST countersink screw (*figure 23*) and the four off M5x8 (two off on right hand side and two off on left hand side) holding the brace container support rear (*figure 23a*) the container support can now be removed by lifting the front of the support and pulling forward to detach it from the lancings on the runner inner beam. (*Figure: 23b*)

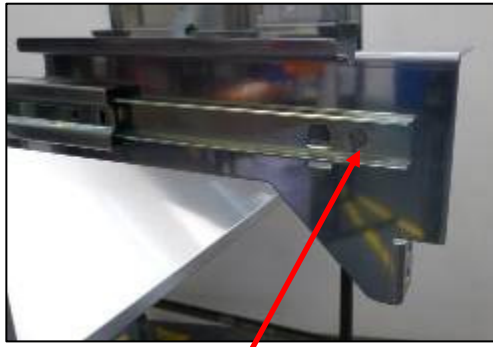

Figure 23: Remove container support retaining screw



Figure 23a: Brace container support rear and four off M5x8

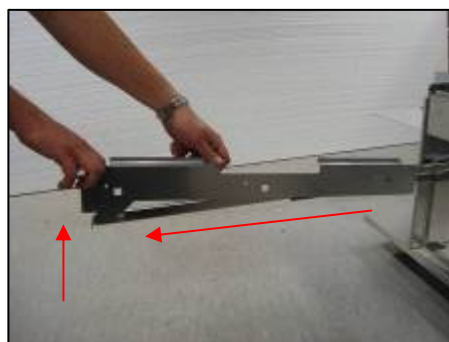

Figure 23b: Removal of container support from the drawer runner.

The runner can now be removed from the drawer, extend the runner slightly, and with a firm grip twist the runner toward the middle of the drawer, this will allow the front of the runner to be lifted clearing the front fastenings, pull the runner forward to clear the rear fixing. See figures below.



Figure 24a: Twist runner.

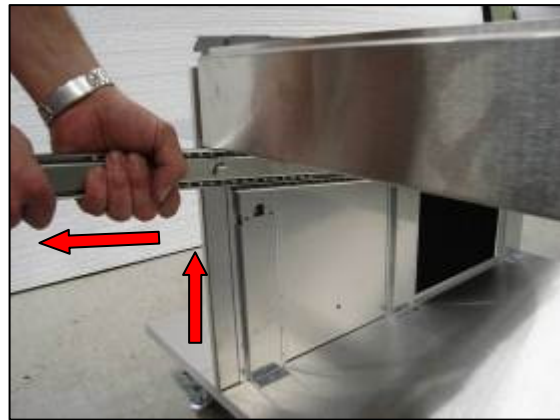

Figure 24b: Lift and pull forward



Figure 24c: Fixings in vertical wall supports and lancing's in runner outer beam

Replacing the runner is the reverse of the removal procedure, engage the rear lancing of the runner in the back vertical wall support and push horizontally to fully engage the rear lancing, engage the middle and front lancing's in their associated vertical wall supports and press down on the runner sharply, it should engage in the front vertical wall support with a 'CLICK', you should now not be able to lift the front of the runner vertically.

Fit the container support in the same way by engaging the rear fixing first with a horizontal motion then engage the front 2 lancing's and press down to fully engaging both, ensure the hole in the front of the runner lines up with the hole in the container support, and refit the M5 X 6 countersink screw, once you have done this you will also need to refit the brace container support rear with four off M5x8 bolts.

If required the runner can be lightly greased with food grade grease.

21 Condenser Fan Replacement

Both the condenser fans should run whenever the compressor is running.

To replace either of the 2 condenser fans the front grille will need to be removed (Chapter 8).

Depending on which fan has failed you will need to disconnect the Earth, Neutral & Live wires from the connectors on the Condenser Fan. Then remove the 4 off M4x45 screws and remove the fan (*figure 24*).

Reverse this procedure to replace the fan ensuring that all the wires are reconnected.



4 Off M4 X45 Br.Zn.Pd. Screws

Figure 24: Condenser Fan mounting

22 Electrical components

Each Adande drawer is fitted with a 6.3amp fuse in the 240v mains supply to the controller, this fuse and holder is situated adjacent to the controller (*Figure 25*) and is accessed by removal of the front grille (Chapter 8).

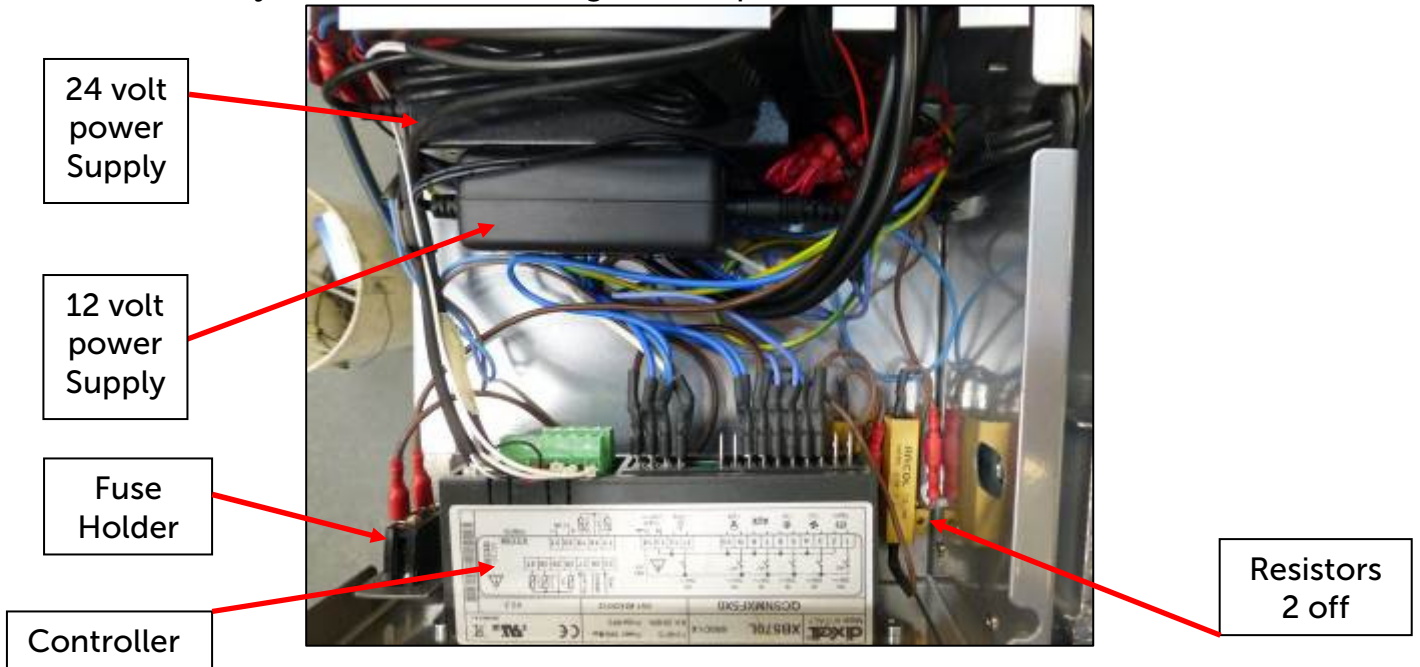

Figure 25: Electrical components

23 Electrical Control System

If replacing items connected to the XB570L Controller then please refer to *figure 26* and the tables below.



Figure 26: Wiring connections to XB570L controller

Dixell XB570L Blast Chill Controller	
1	
2	
3	230 volt live to 12 volt power supply
4	230 volt neutral to 12 volt power supply
5	230 volt live to Defrost heater
6	230 volt Defrost heater neutral
7	230 volt live to 24 volt power supply
8	230 volt neutral to 24 volt power supply
9	
10	
11	Compressor and condenser fan 230 volt live
12	Compressor and condenser fan 230 volt neutral
13	230 volt Live mains supply to controller
14	230 volt mains neutral
17	
18	
19	
20	
21	
25	Drawer switch
26	Drawer switch
27	
28	Defrost temperature probe
29	Common temperature 3 off temperature probes
30	Drawer temperature probe
31	Insert temperature probe





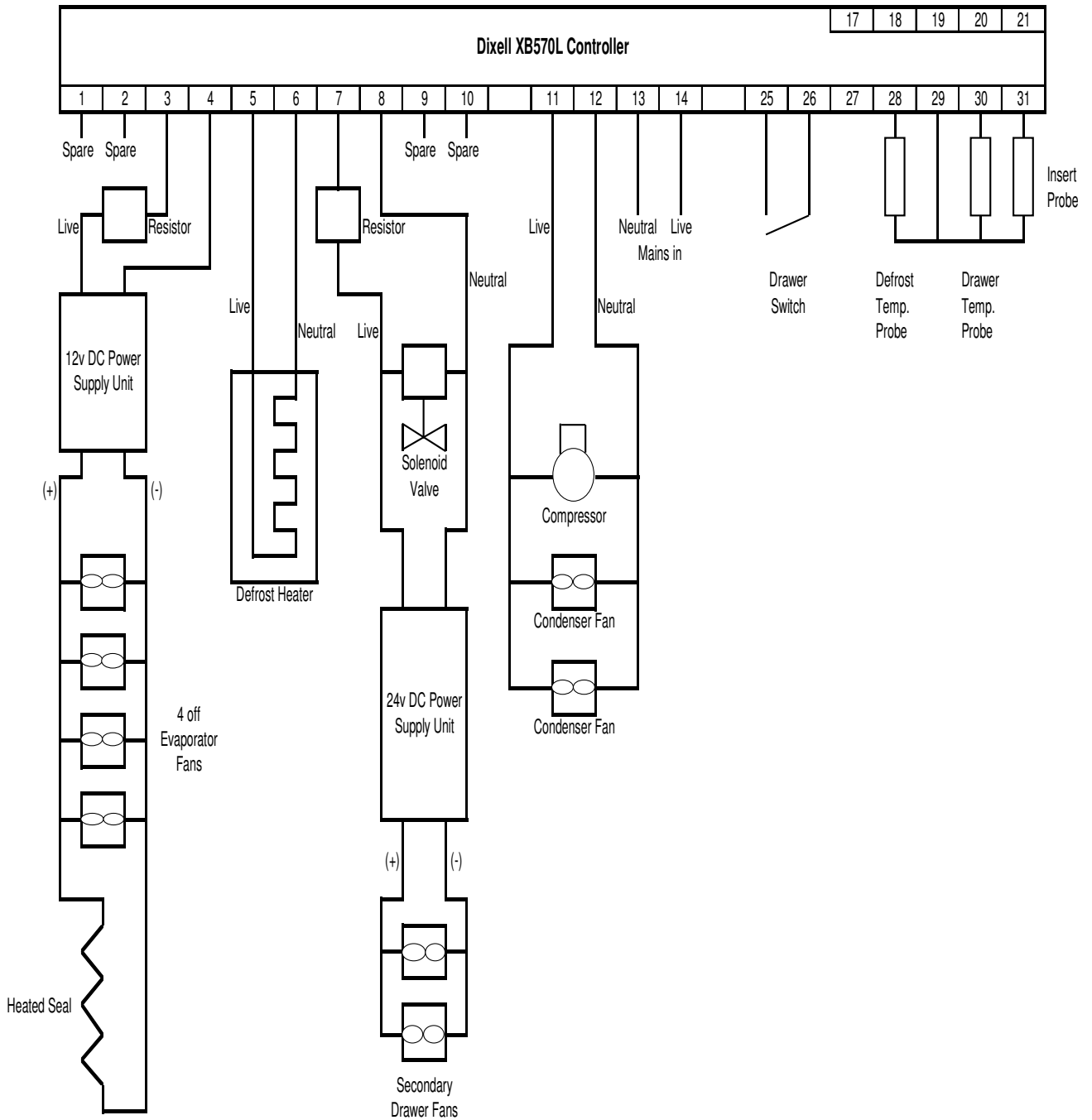

23.1 Wiring Diagram for Dixell XB570L Blast Chill Controller

Wiring Diagram for Dixell XB570L Blast Chill Controller





(——— Not used ———)



24 How to enter Settings on Dixell XB570L Blast Chill Controller

- 1) Hold  +  to enter programming mode
- 2) Pr11st Level
- 3) Pr22nd Level protected by password (321)
- 4)  To progress in the list of settings
- 5)  +  +  to modify setting (the parameter appears flashing)
- 6)  To store the setting

24.1 How to enter settings for each cycle

- 1)  Press to select the desired cycle
After having a cycle selected the cycle number appears  illuminated
- 2) Press and hold  until the light becomes visible and the first parameter of the cycle (CyS) is displayed
- 3) To modify and store the setting use the same keys as in the 1st and 2nd level programming Menu i.e. steps 5 & 6 on the section above
- 4)  +  to return to the previous menu
- 5) Repeat steps 7 to 9 for the remaining cycles

24.2 Settings for Dixell XB570L Blast Chill Controller

Variable			Value	Units	Description
		Set point	-21		
		Hy	1		Hysteresis
		tCy		Read only	Cycle duration
Pr1		tP1		Read only	First phase duration
		tP2		Read only	Second phase duration
		tP3		Read only	Third phase duration
Pr2					Installer parameters
	PAS		321		Pass code
Parameters					
		Hy	1		Hysteresis
		AC	1		Anti-short cycle
		PAU	0		Time of standby
		PFt	15		Maximum acceptable duration of power failure
		Con	15		Compressor on time with faulty probe
		COF	15		Compressor off time with faulty probe
Probes					
		rPO	0		Thermostat probe calibration
		EPP	Yes		Evaporator probe presence
		EPO	0		Evaporator probe calibration
		i1P	Yes		Insert probe 1 presence
		i1O	0		Insert probe 1 calibration
		i2P	No		Insert probe 2 presence
		i2O	0		Insert probe 2 calibration
		i3P	No		Insert probe 2 presence
		i3O	0		Insert probe 2 calibration
		rEM	rPt		Probe selection to stop chilling cycle
Display and measurement unit					
		CF	°C		Temperature measurement units
		rES	dE		Resolution
		Lod	rP		Local display
		rEd	rP		Remote display

Variable			Value	Units	Description
Digital inputs					
		d1P	OP		Drawer switch polarity
		Odc	F-C		Open drawer control
		dOA	5		Open drawer alarm delay
		dLc	Yes		Stop count down of running cycle
		rrd	No		Regulation restart after door open alarm
		d2F	EAL		Second digital input function
		d2P	cL		Second digital input polarity
		did	15		Time delay for digital input alarm
Auxiliary relay configuration					
		oA1	C2		First configurable relay function
		oA2	ALL		Second configurable relay function
		oA3	Lig		Second configurable relay function
Second relay management					
		2CH	C1		Compressor setting during the holding
		OAt	0		Second compressor switching on delay
		OAS	0.1		Set point for second compressor
		OAH	0.1		Differential for second compressor
		OAi	rP		Probe selection for second compressor
Auxiliary relay management					
		OSt	0		Auxiliary output timer
		OSS	-30		Set point for auxiliary output
		OSH	0.1		Differential for auxiliary output
		OSi	rP		Probe selection for auxiliary output
Defrost					
		tdF	rE		Defrost type
		ldF	8		Interval between defrost cycles
		dtE	8		Defrost termination temperature
		MdF	25		Maximum length for defrost
		dFd	DEF		Temperature displayed during defrost
		Fdt	6		Drip time
		dAd	30		Defrost display time out
Fans					
		FnC	O-n		Fans operating mode
		FSt	20		Fan stop temperature
		AFH	1		Differential for stop temperature and alarm
		Fnd	2		Fan delay after defrost

Variable			Value	Units	Description
Temperature alarms					
		ALU	7		Maximum temperature alarm
		ALL	7		Minimum temperature alarm
		ALd	30		Temperature alarm delay
		EdA	30		Temperature alarm delay at end of defrost
		tbA	Yes		Silencing alarm relay
Other					
		tCy		Read Only	Cycle duration
		tP1		Read Only	First phase duration
		tP2		Read Only	Second phase duration
		tP3		Read Only	Third phase duration
		Adr	-		Address for RS485
		bUt	60		Buzzer activation at the end of the cycle
		tPb	NTC		Type of probe
		rEL	-		Release code
		Ptb	-		Parameter code
		dP2	-		

Cycles					
Cy1 - Soft Chill (90 minutes)				Cycle 1 settings	
		CyS	tiM		Cycle setting
		dbC	No		Defrost before cycle
		iS1	0		Insert probe set point first phase
		rS1	-15		Room probe set point first phase
		Pd1	Off		Maximum time for first phase
		iS2	0		Insert probe set point second phase
		rS2	-1		Room probe set point second phase
		Pd2	1.3		Maximum time for second phase
		iS3	0		Insert probe set point third phase
		rS3	0		Room probe set point third phase
		Pd3	Off		Maximum time for third phase
		dbH	Yes		Defrost before holding cycle
		HdS	3		Set point for holding phase

Variable			Value	Units	Description
	Cy2 - Hard Chill (90 minutes)				Cycle 2 settings
		CyS	tiM		Cycle setting
		dbC	No		Defrost before cycle
		iS1	0		Insert probe set point first phase
		rS1	-15		Room probe set point first phase
		Pd1	1.0		Maximum time for first phase
		iS2	0		Insert probe set point second phase
		rS2	-1		Room probe set point second phase
		Pd2	0.3		Maximum time for second phase
		iS3	0		Insert probe set point third phase
		rS3	0		Room probe set point third phase
		Pd3	Off		Maximum time for third phase
		dbH	Yes		Defrost before holding cycle
		HdS	3		Set point for holding phase
	Cy3 - Soft Chill (120 minutes)				Cycle 3 settings
		CyS	tiM		Cycle setting
		dbC	No		Defrost before cycle
		iS1	0		Insert probe set point first phase
		rS1	-15		Room probe set point first phase
		Pd1	Off		Maximum time for first phase
		iS2	0		Insert probe set point second phase
		rS2	-1		Room probe set point second phase
		Pd2	2.0		Maximum time for second phase
		iS3	0		Insert probe set point third phase
		rS3	0		Room probe set point third phase
		Pd3	Off		Maximum time for third phase
		dbH	Yes		Defrost before holding cycle
		HdS	3		Set point for holding phase
	Cy4 - Hard Chill (120 minutes)				Cycle 4 settings
		CyS	tiM		Cycle setting
		dbC	No		Defrost before cycle
		iS1	0		Insert probe set point first phase
		rS1	-15		Room probe set point first phase
		Pd1	1.3		Maximum time for first phase
		iS2	0		Insert probe set point second phase
		rS2	-1		Room probe set point second phase
		Pd2	0.3		Maximum time for second phase
		iS3	0		Insert probe set point third phase
		rS3	0		Room probe set point third phase
		Pd3	Off		Maximum time for third phase
		dbH	Yes		Defrost before holding cycle
		HdS	3		Set point for holding phase

25 Refrigeration maintenance

A standard hermetically sealed R404a vapour compression refrigeration circuit is used in the Adande® drawer system and should need minimum maintenance.

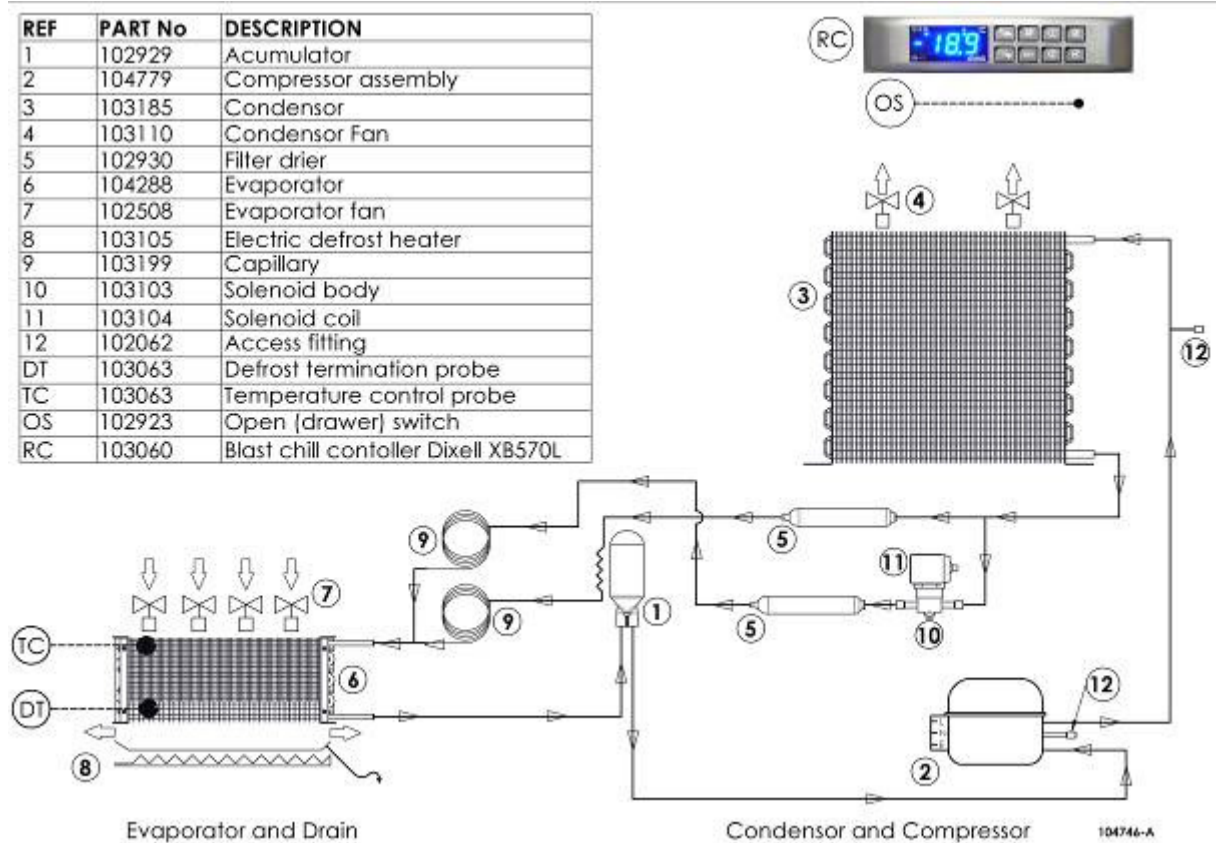

Figure 28: Refrigeration circuit diagram

The unique design for airflow over the condenser means that the majority of any airborne contaminants are deposited on the easily cleaned surfaces of the drawer cabinet and the insulated container.

In the unlikely event of the condenser becoming blocked, it can be easily accessed by removing the insulated container and cleaned in the normal way.

26 Drawer configuration

Any drawer of the Adande® Side Engine Drawer Fridge (VCS) can be configured as a blast chiller.

Below are some examples of single, two and three drawer options.



VCS1HCHS

- Single drawer
- High castor base
- Heat shielding worktop

This arrangement is intended to support a grill or oven.



VCS2CT

- Two drawer
- Standard castor base
- Top cover

The top cover is a non load bearing cover.

This arrangement is intended for under counter installations



VCS3CW

Three drawer
Castor base
Worktop



VCS2CM

Two drawer Castor base
Microwave station
(Optional can opener)



Blast chiller drawer



Lockable drawer front

27 Fault Finding

27.1 Drawers not operating correctly

Possible Cause	Recommended Action
Runners require lubrication	Lubricate runners, see Chapter 20
Runners are mechanically damaged	Replace runners, see Chapter 20
Seal is being over compressed	Readjust lid height, see Chapter 19
Ice build up causing diffuser to hit insulated container	Check defrost heater operation and drain for blockages see Chapter 16

27.2 Seals and/or insulated container rim have ice and condensation

Possible Cause	Recommended Action
Seal is contaminated	Clean the seal
Seal damaged	Replace seal, see Chapter 18
Seal heater is not working	a) Check 12 v power supply b) Check seal heater continuity, Replace seal if faulty, see Chapter 18 c) Check resistor has not failed.
Seal compression is inadequate	Readjust lid height, see Chapter 19
Product/packaging trapped between insulated container rim and lid distorting seal	Ensure stored product is below Max Fill line in insulated container.

27.3 Drawer is not maintaining set temperature

Possible Cause	Recommended Action
Failure of evaporator fans	a) Check drawer switch operation b) Check 12v power supply c) Check evaporator fans. Replace evaporator fans if necessary, see Chapters 12, 13, and 14
Seal failure	Check condition of drawer seal
Excessive icing of evaporator coil	a) Check defrost operation b) Check defrost heater operation c) Manually defrost d) Check/clean drain from evaporator e) Check orientation of drain tray f) Check seal condition g) Check lid height
Drawer temperature probe faulty	Replace temperature probe
Defrost termination probe faulty	Replace temperature probe
Blocked capillary line	Replace capillary tube.
Low refrigerant	Search for leak in system, repair leak and recharge unit with refrigerant
Failure of condenser fan	Check the condenser fan is operational, see Chapter 21
Condenser coil is blocked	Clean condenser coil
Failure of compressor	Replace compressor if faulty.

27.4 The drawer does not power up

Possible Cause	Recommended Action
Fuse has failed in mains plug	Check fuse, if it has failed investigate for possible cause before fitting new 13A fuse.
Fuse has failed within unit	Check 7 amp fuse – see Chapter 21
No mains power at mains terminals	If mains fuse OK then check wiring of the plug. Ensure power is switched off at socket.
Plugs into drawer not fully inserted	Check all plugs/ sockets ensure 'P' clips correctly fitted.

27.5 Evaporator fans continue to run when drawer is open

Possible Cause	Recommended Action
Controller has failed.	Replace Controller

27.6 Evaporator fans do not run when drawer is closed

Possible Cause	Recommended Action
Drawer switch has failed	Replace switch
12 v power supply failed	Check 12v power supply Check wiring to fans for damage Check resistor has not failed.

27.7 Blast chill cycle fails to operate

Problem	Recommended Action
Secondary fans not running	Check nothing stuck in fans Check fans have not seized Check 24 volt power supply Check resistor has not failed.
Secondary fans run but drawer not cooling	Check solenoid valve operating correctly Temperature probe failure – check probes Check that secondary capillary is not blocked
Secondary fans run continually	Controller failure – replace controller

28 Exploded diagrams

28.1 Housing spare parts

HOUSING

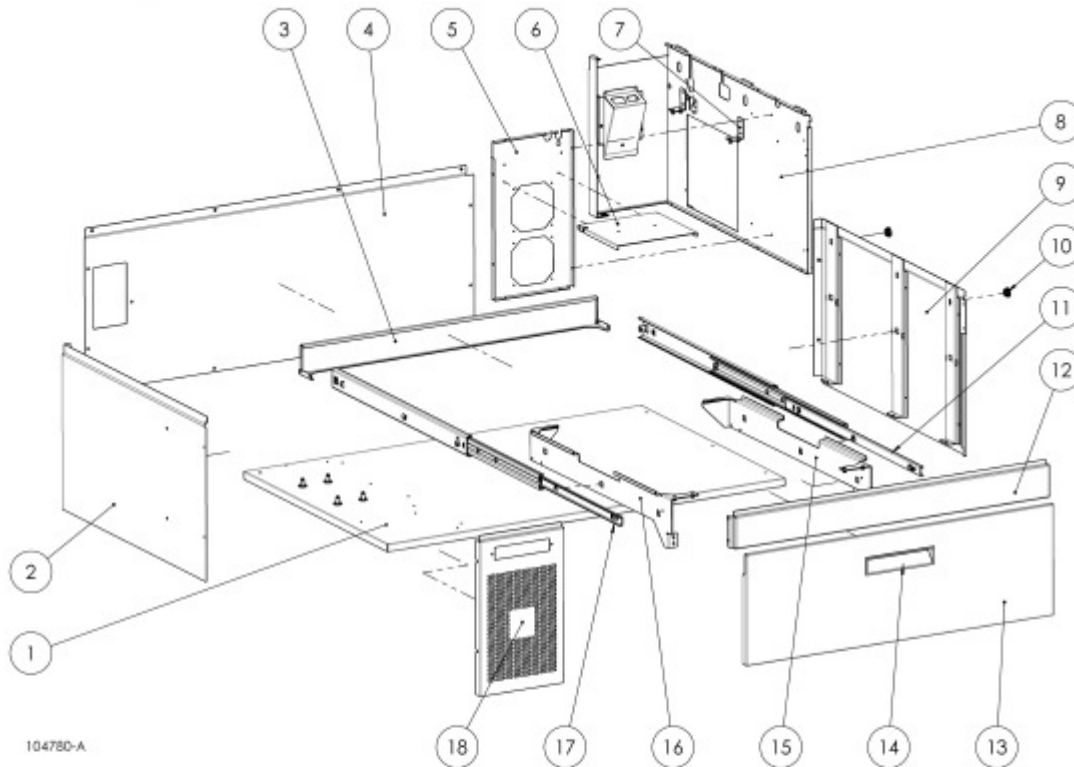

104780-A

Item	Part No.	Description	Item	Part No.	Description
1	103706	PANEL HOUSING BASE	10	103292	PLUG BUTTON SNAP-IN
2	103718	PANEL HOUSING LH	11	104741	DRAWER SLIDE RH
3	104715	BRACE CONTAINER SUPPORT REAR	12	103716	CHANNEL UPPER FRONT
4	103717	PANEL HOUSING REAR	13	103734	DRAWER FRONT ASSEMBLY
5	103464	FAN MOUNTING PLATE	14	103694	RECESSED DRAWER PULL
6	103712	PANEL LOWER CONTROLS	15	103721	SUPPORT RH ADANDE CONTAINER
7	103719	BRACKET CONDENSER SUPPORT	16	103722	SUPPORT LH ADANDE CONTAINER
8	103707	COMMON WALL S/W ASSEMBLY	17	104740	DRAWER SLIDE LH
9	103713	PANEL HOUSING RH ASSEMBLY	18	103515	PANEL CONTROLLER & LOUVRE

28.2 Fridge, Electrical System and drawer parts

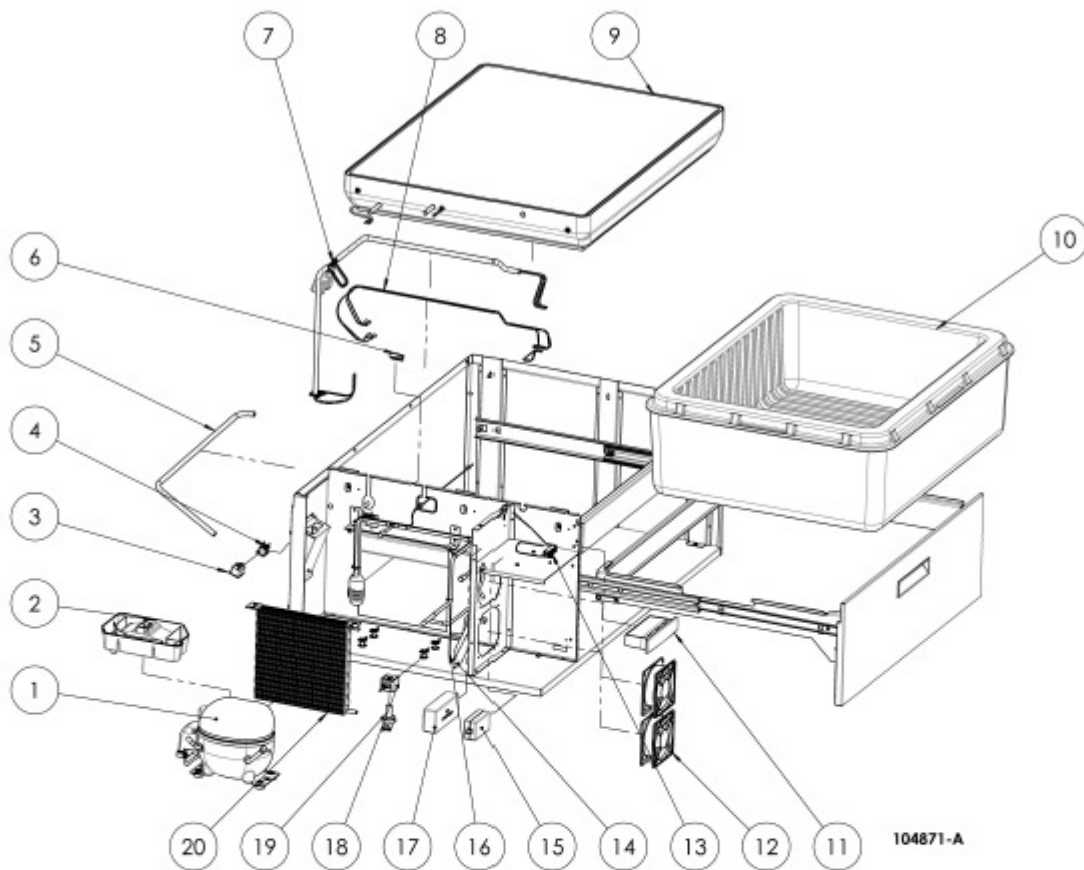

104871-A

Item	Part No.	Description	Item	Part No.	Description
1	104779	COMPRESSOR NEK2130GK ASSEMBLY	11	103060	DEFROST CONTROLLER
2	102945	EVAPORATOR TRAY	12	103008	FAN AXIAL
3	102922	POWER OUTLET IEC	13	103446	RESISTOR
4	102921	POWER INLET IEC	14	102930	FILTER DRIER
5	102976	DRAIN PIPE	15	103511	POWER SUPPLY 12V ASSEMBLY
6	102923	DRAWER SWITCH	16	103199	CAPILLARY
7	103621	HARNES MAIN POWER INTERNAL	17	103512	24V POWER SUPPLY
8	103030	HARNES SWITCH & SEAL HEATER	18	103104	SOLENOID COIL
9	103112	INSULATED LID BUILT ASSEMBLY	19	103103	SOLENOID BODY
10	102216	INSULATED CONTAINER	20	103185	CONDENSER

28.3 Insulated Lid (part No. 103013 – Complete Assembly)

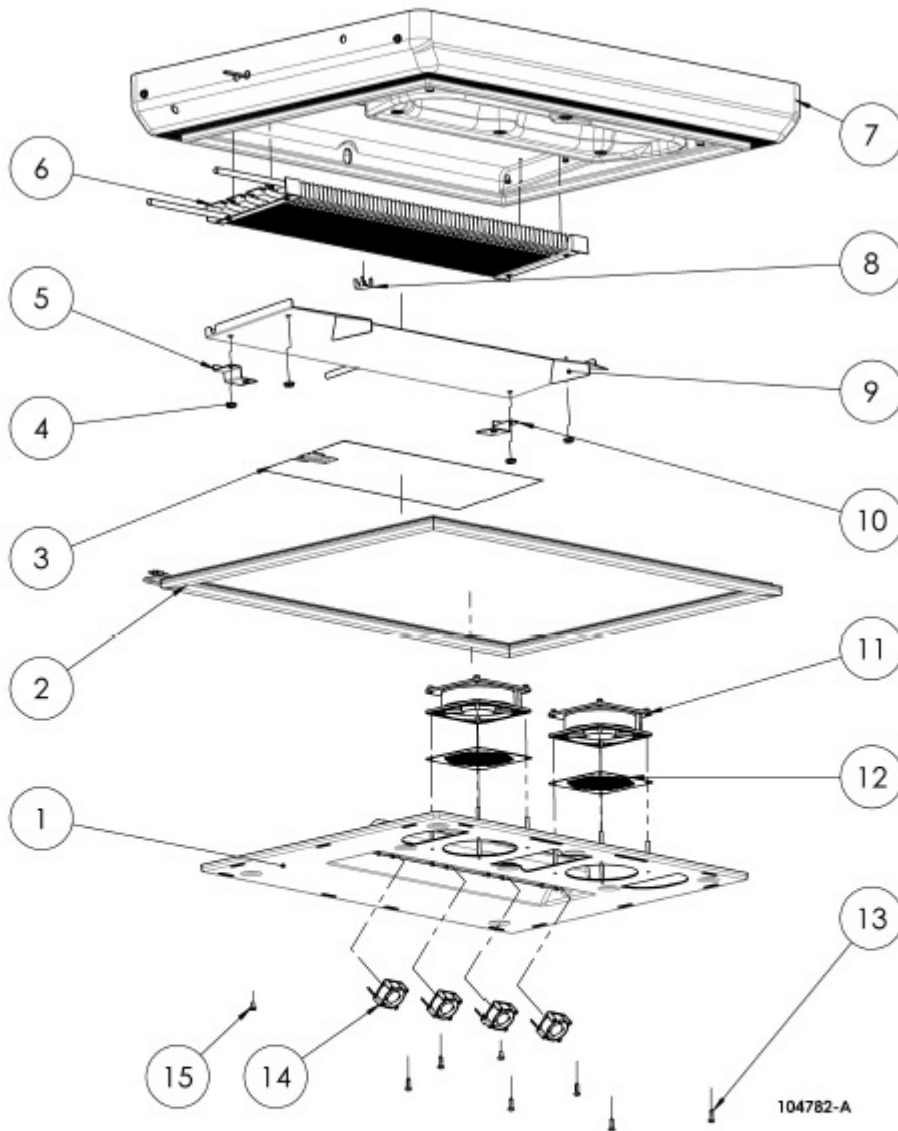

Item	Part No.	Description	Item	Part No.	Description
1	103114	LID DIFFUSER	8	103760	BRACKET CLIP-ON C/TRAY SPACER
2	103746	CONTAINER SEAL HEATED MAGNETIC	9	103079	PLATE DEFROST COLLECTION
3	103105	DEFROST HEATER ELECTRIC	10	103784	BRACKET DIFFUSER FIXING RH
4	103491	WASHER ST/ST BONDED	11	103110	FAN AXIAL 119mm x 38mm
5	103785	BRACKET DIFFUSER FIXING LH	12	104315	FINGER GUARDS 119mm
6	104288	EVAPORATOR COIL PAINTED	13	103092	UNSCREWING SNAP RIVET
7	103111	INSULATED LID	14	102508	EVAPORATOR FAN
			15	103596	SCREW SLOTTED PAN M5x8 ST/ST

28.4 C - BASE - Standard Castors (Part No. 102992 – complete assembly)

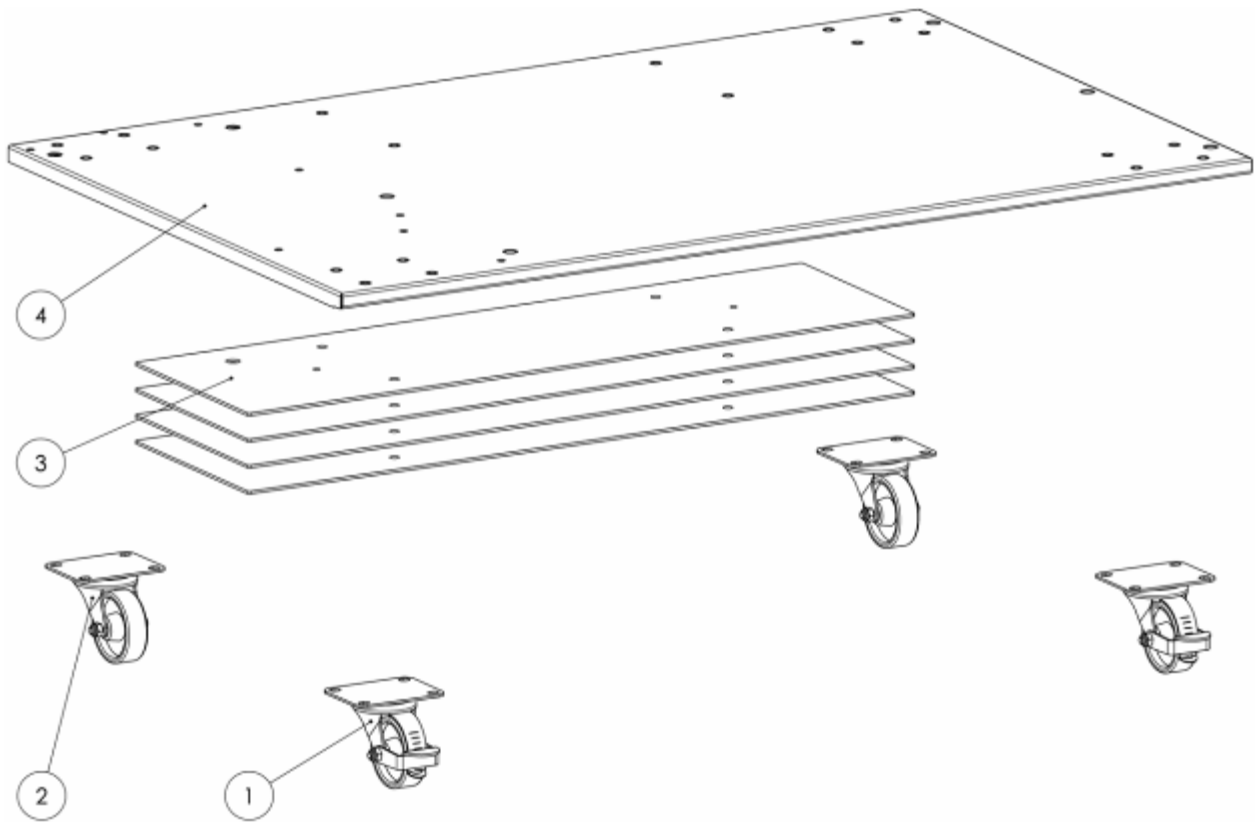

Item	Part No.	Description
1	102517	SWIVEL CASTOR 75mm WITH BRAKE
2	102516	SWIVEL CASTOR 75mm
3	102905	PANEL COUNTERBALANCE
4	102889	PANEL BASE CASTOR TROLLEY

28.5 HC – BASE - High Castors (Part No. 103506– complete assembly)

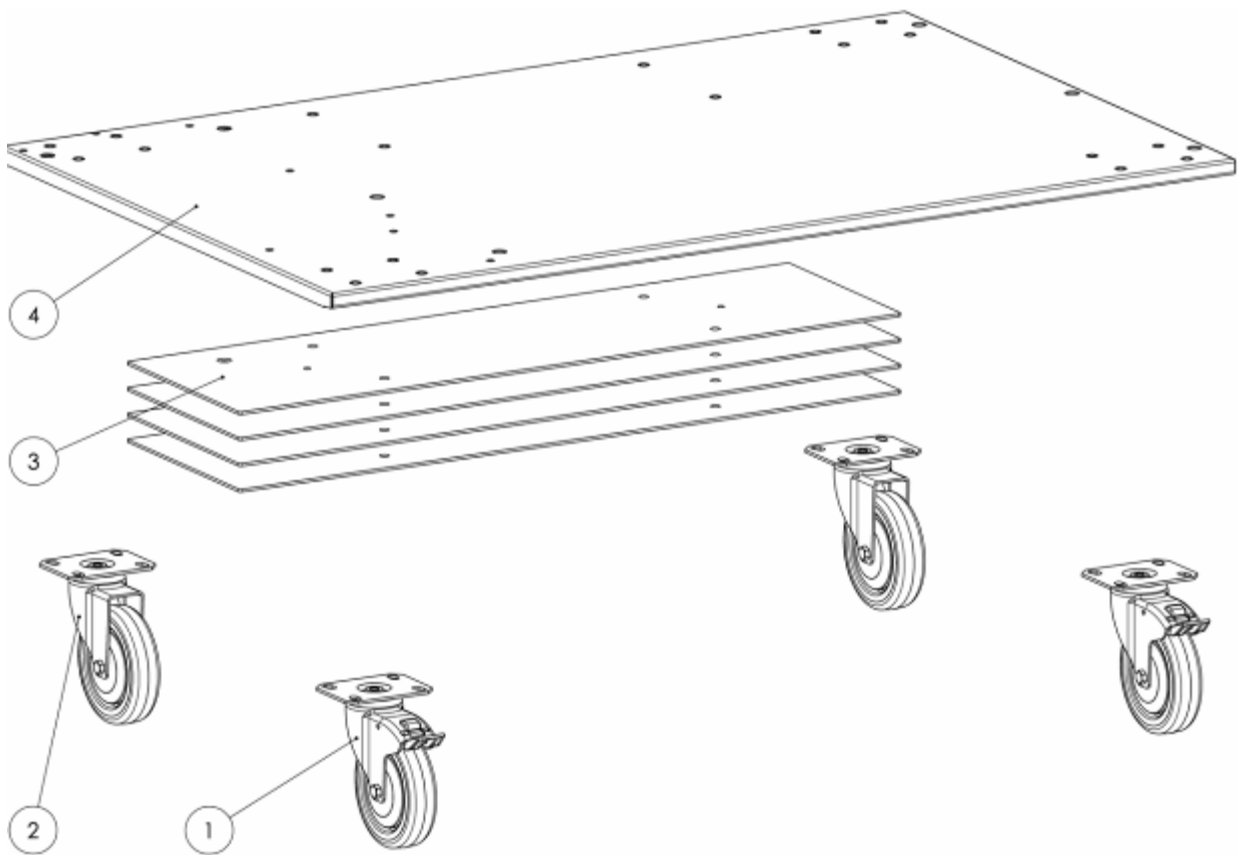

Item	Part No.	Description
1	103502	SWIVEL CASTOR 125mm WITH BRAKE
2	103501	SWIVEL CASTOR 125mm
3	102905	PANEL COUNTERBALANCE
4	102889	PANEL BASE CASTOR TROLLEY

28.6 SC – BASE - Small Castors (Part No. 103535– complete assembly)

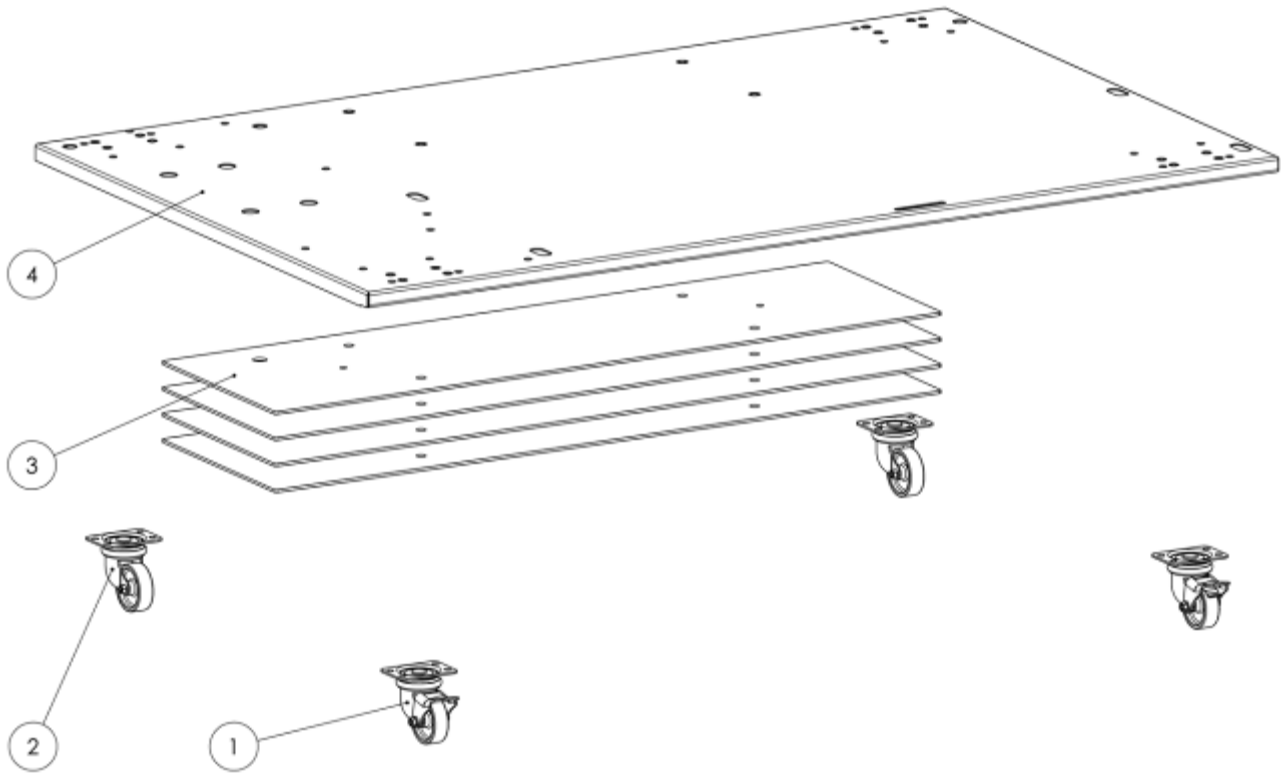

Item	Part No.	Description
1	103524	SWIVEL CASTOR BRAKED 50mm
2	103523	SWIVEL CASTOR 50mm
3	102905	PANEL COUNTERBALANCE
4	103522	PANEL BASE 50mm CASTOR TROLLEY

28.7 DC- BASE - Double Castor with Adapter (Part No. 103465 – complete assembly)

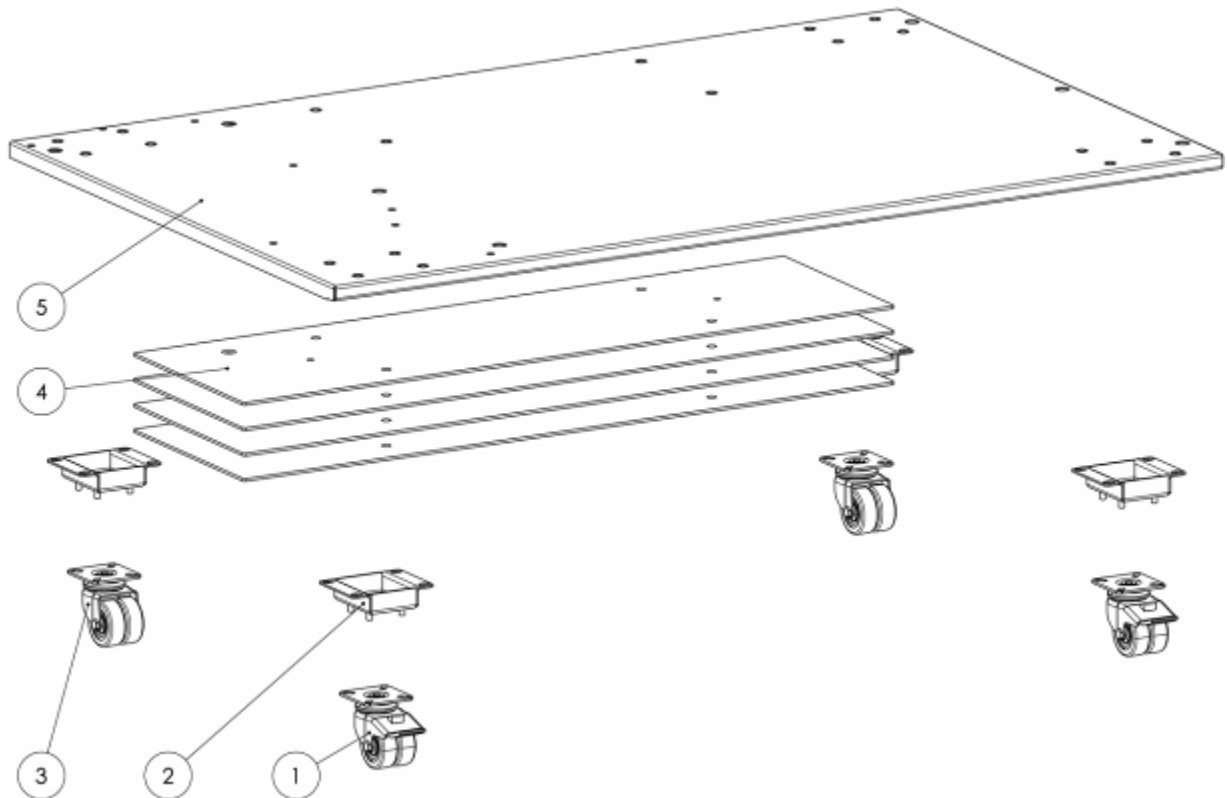

Item	Part No.	Description
1	103376	SWIVEL CASTOR DOUBLE WHEEL BRAKED
2	103372	BRACKET ADAPTER CASTOR FITTING
3	103375	SWIVEL CASTOR DOUBLE WHEEL
4	102905	PANEL COUNTERBALANCE
5	102889	PANEL BASE CASTOR TROLLEY

28.8 R – BASE - Rollers rear, Feet front (Part No. 102993 – complete assembly)

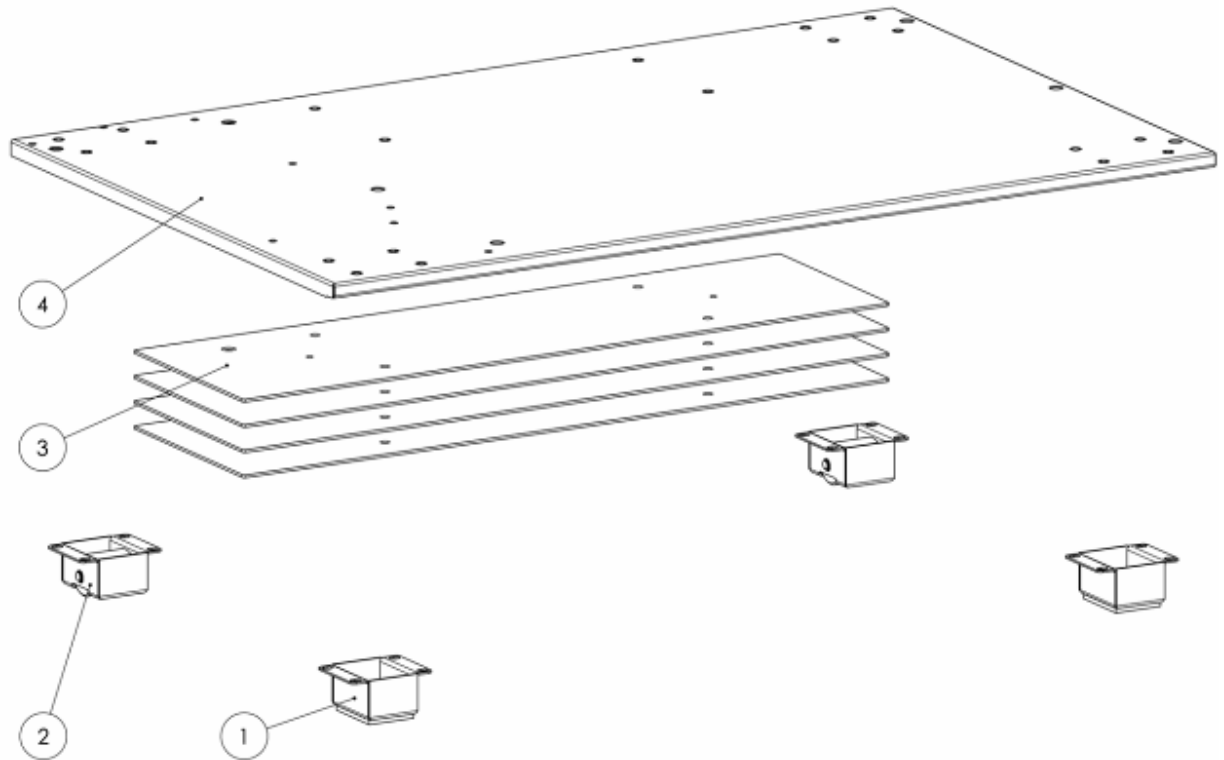

Item	Part No.	Description
1	103007	FOOT SUPPORT 50MM ASSEMBLY
2	102955	ROLLER ASSEMBLY
3	102905	PANEL COUNTERBALANCE
4	102889	PANEL BASE CASTOR TROLLEY

28.9 SR – BASE - Small Rollers rear, Small Feet front (Part No. 103393 – complete assembly)

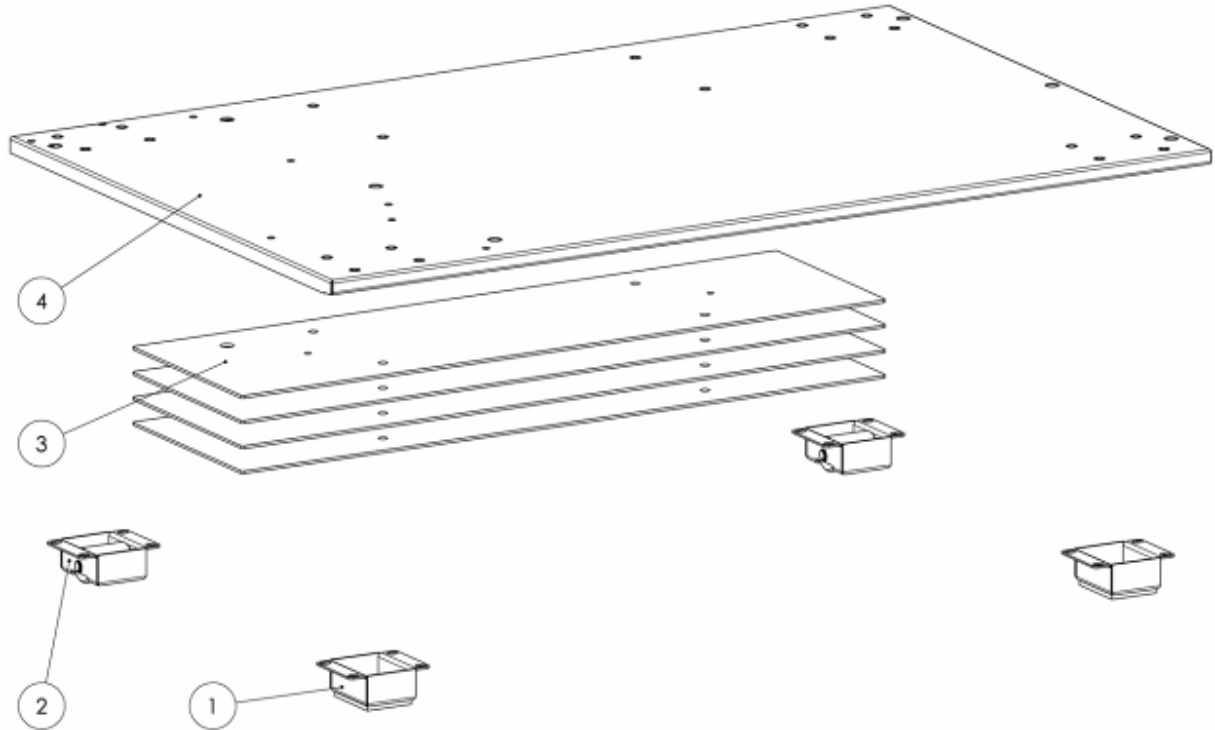

Item	Part No.	Description
1	103229	FOOT SUPPORT 40MM ASSEMBLY
2	103232	ROLLER SMALL ASSEMBLY
3	102905	PANEL COUNTERBALANCE
4	102889	PANEL BASE CASTOR TROLLEY

28.10 T - Top cover

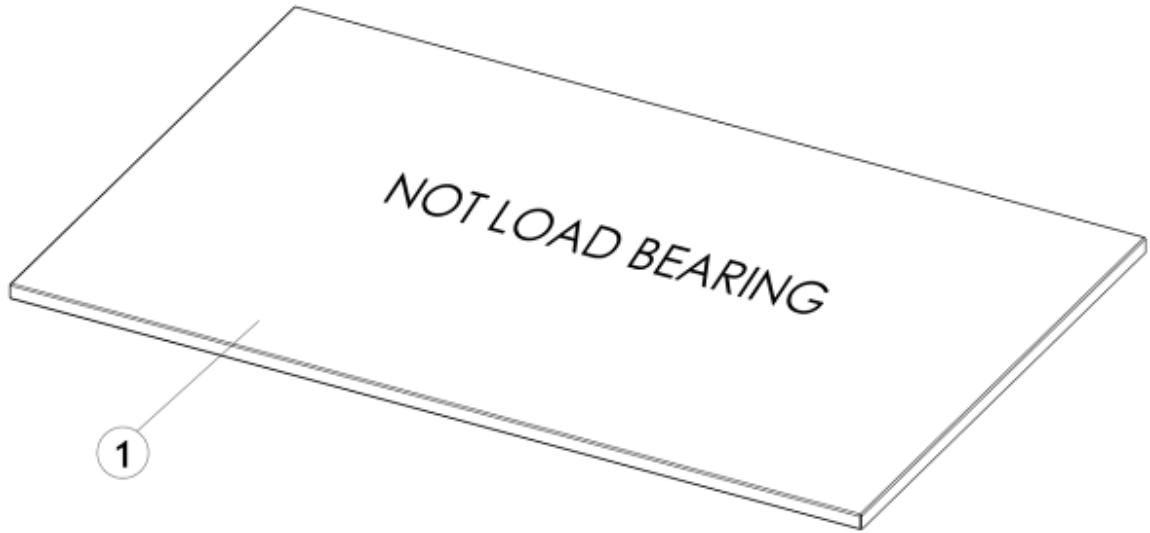

Item	Part No.	Description
1	103034	TOP COVER

28.11 W - Worktop (shown with optional 50mm up stand)

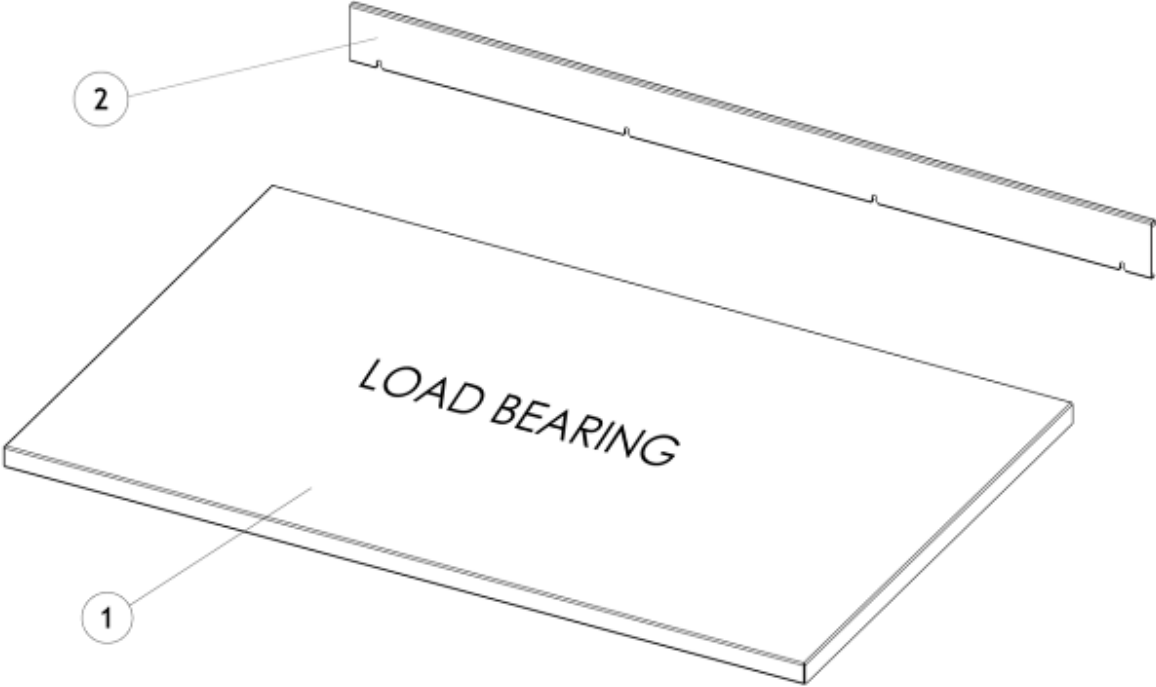

Item	Part No.	Description
1	102949	WORKTOP
2	103056	UPSTAND

28.12 HS - Heat shield top

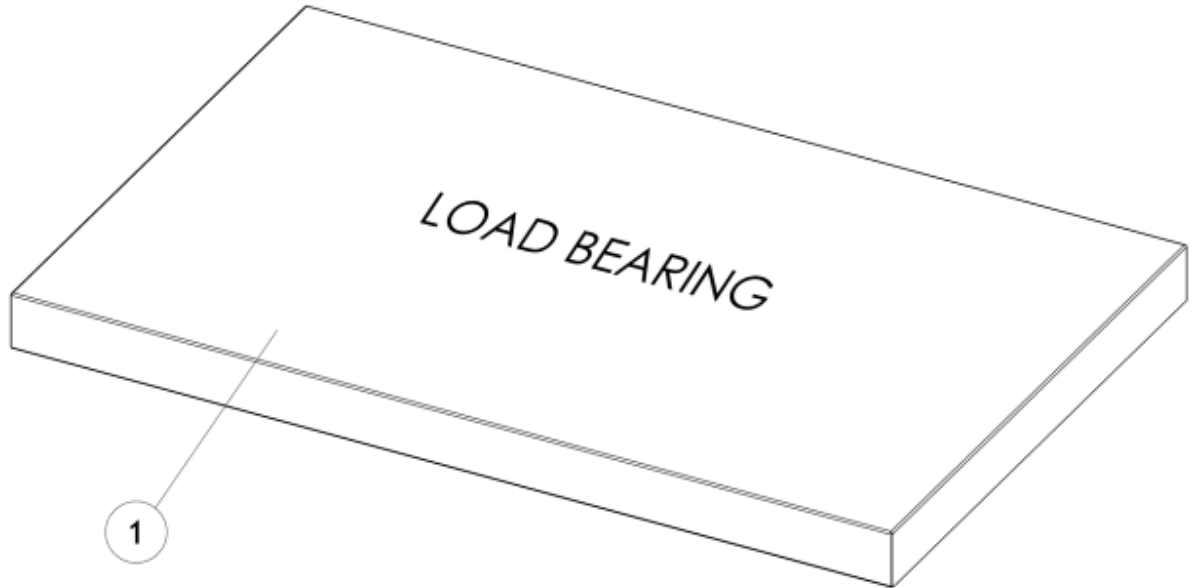

Item	Part No.	Description
1	103570	HEAT SHIELD TOP